

# ACE

## Electric Forklift

**Capacity : 4.5-6 tonnes**  
**Power : Battery Operated**

High Performance & rugged  
Electric Forklift Trucks.



**INDIA'S NO. 1  
CRANE BRAND**





## SPECIFICATIONS

Model	UNITS	AF45E		AF50E		AF60E	
Power		Electric					
Load Capacity	kg	4500		5000		6000	
Load Center	mm	500		500		500	
Fork Height (std.)	mm	3000					
Fork Size (LxWxT)	mm	1070x150x50		1070x150x50		1070x150x50	
Tilt Angle	deg	6°/9°		6°/9°		6°/9°	
Overall Width	mm	1600		1600		1600	
Overhead Guard Clearance	mm	160		160		160	
Overall Length	mm	3100		3100		3100	
Wheel Base	mm	2000		2000		2000	
Ground Clearance	mm	160		160		160	
Turning Radius	mm	2817		2817		2817	
Travel Speed (With/Without Load)	kmph	13	14	13	14	13	14
Lifting Speed (With/Without Load)	mm/s	250	300	220	300	220	300
Gradeability (With/Without Load)	%	15	15	15	15	15	15
Operating Weight	kg	7500		7800		8200	
Wheel (s)		4					
Tyre Size	FRONT	2.8x12.5-15-24PR					
	REAR	7.00-12-14PR					
Drive Motor	kw	9.1x2 AC		9.1x2 AC		9.1x2 AC	
Pump Motor	kw	12x2 AC		12x2 AC		12x2 AC	
Steering Type		Hydraulic					
Battery rating	V/Ah	80/600		80/700		80/800	
Electronic Controller		CURTIS					

## MAST DETAILS

MASTTYPE	MAX FORK HEIGHT (mm)	LOAD CAPACITY AT MFH (KGS)			OVERALL HEIGHT LOWERED (mm)			FREE LIFT (mm) (without backrest)			TILT ANGLE (α/β)
		AF 45E	AF 50E	AF 60E	AF 45E	AF 50E	AF 60E	AF 45E	AF 50E	AF 60E	
Double Mast (Std.)	3000	4500	5000	6000	2270	2270	2370	150	150	150	6/9
Double Mast (Fullfree) *	3000	4500	5000	6000	2270	2270	2370	1445	1445	1445	6/9
Double Mast (Std.)	3700	4500	4800	5400	2620	2620	2720	150	150	150	6/9
Triple Mast (Fullfree) *	4500	3900	4200	4500	2270	2270	2370	1460	1460	1460	6/6
Triple Mast (Fullfree)	6000	2200	2400	2600	2870	2870	2970	2215	2215	2215	3/6

\* – Suitable for container stuffing

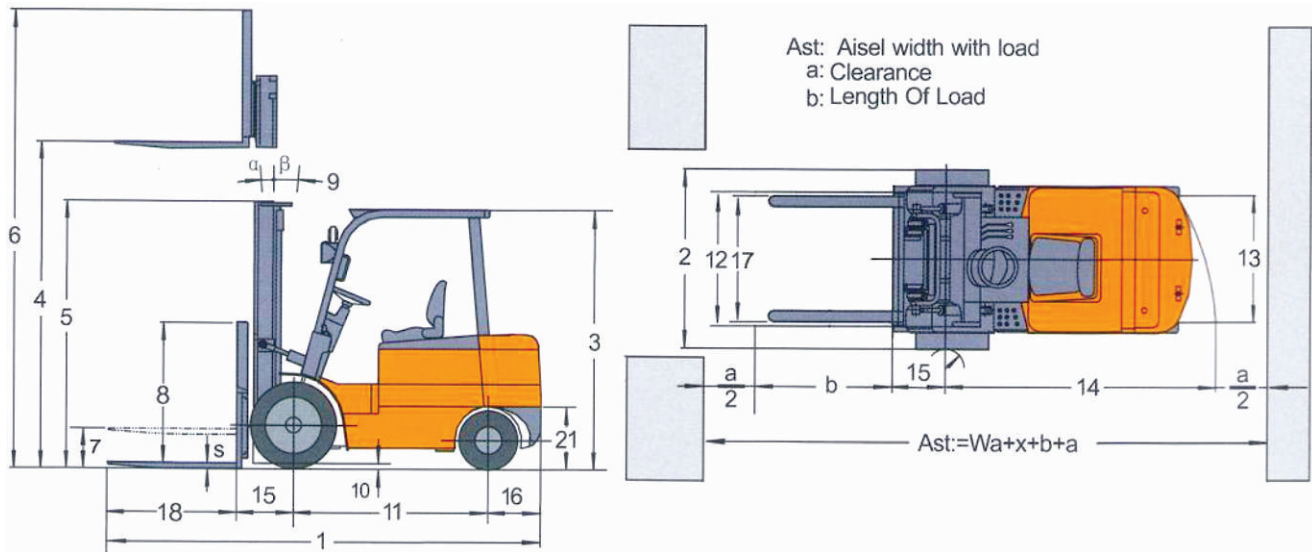

## STANDARD DIMENSIONS

	Model	AF45E	AF50E	AF60E
1	Overall Length (with Fork)	4170	4170	4170
2	Overall width	1600	1600	1600
3	Overall Height (Overhead Guard)	2255	2255	2255
4	Lifting Height (std.)	3000	3000	3000
5	Overall height fork lowered	2270	2270	2370
6	Overall height fork lowered (With Backrest)	4165	4165	4160
7	Free Lift	150	150	150
8	Backrest height (from upper face of forks)	1120	1120	1120
9	Tilting Angles	6/9	6/9	6/9
10	Min. Clearance (bottom of mast)	160	160	160
11	Wheel Base	2000	2000	2000
12	Trade (Front)	1280	1280	1280
13	Trade (Rear)	1190	1190	1190
14	Outside turning radius	2817	2817	2817
15	Fork overhung	565	565	565
16	Rear overhung	535	535	535
17	Lateral fork adjustment	300-1370	300-1370	300-1370
18	Fork length	1070	1070	1070
19	Fork width	150	150	150
20	Fork thickness	50	50	50
21	Coupler height	725	725	725
22	Min. intersecting aisle	2955	2955	2955

\* RASA = Right Angle stacking Aisle.

\* All dimension in mm.



# FORKLIFTS

## Forklifts

### LOAD CHART

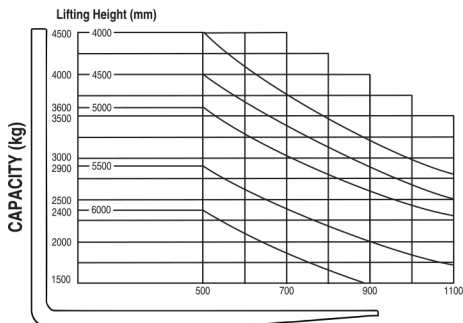

AF 45 E

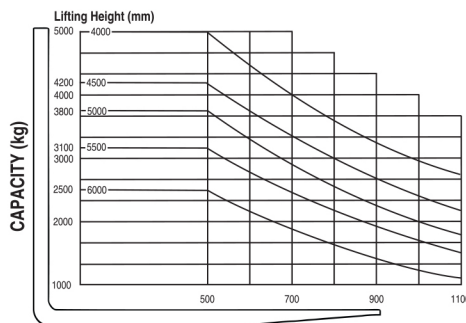

AF 50 E

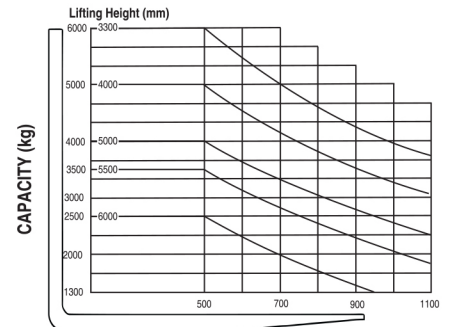

AF 60 E



### ATTACHMENTS





# COMPLETE MATERIAL HANDLING SOLUTION

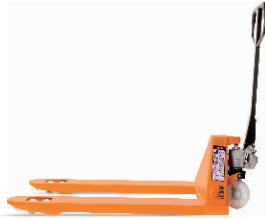

*Nothing beats an **ACE***



## Electric Forklifts



1.5T - 3.0T



4.5T - 6.0T

## Diesel Forklifts



1.5T - 3.0T



4.0T - 10T



12T - 35T

## LPG Forklifts



3.0T - 5.0T

# BUILT TO PERFORM



**RELIABLE AND  
DEPENDABLE  
EFFICIENCY**

## NETWORK

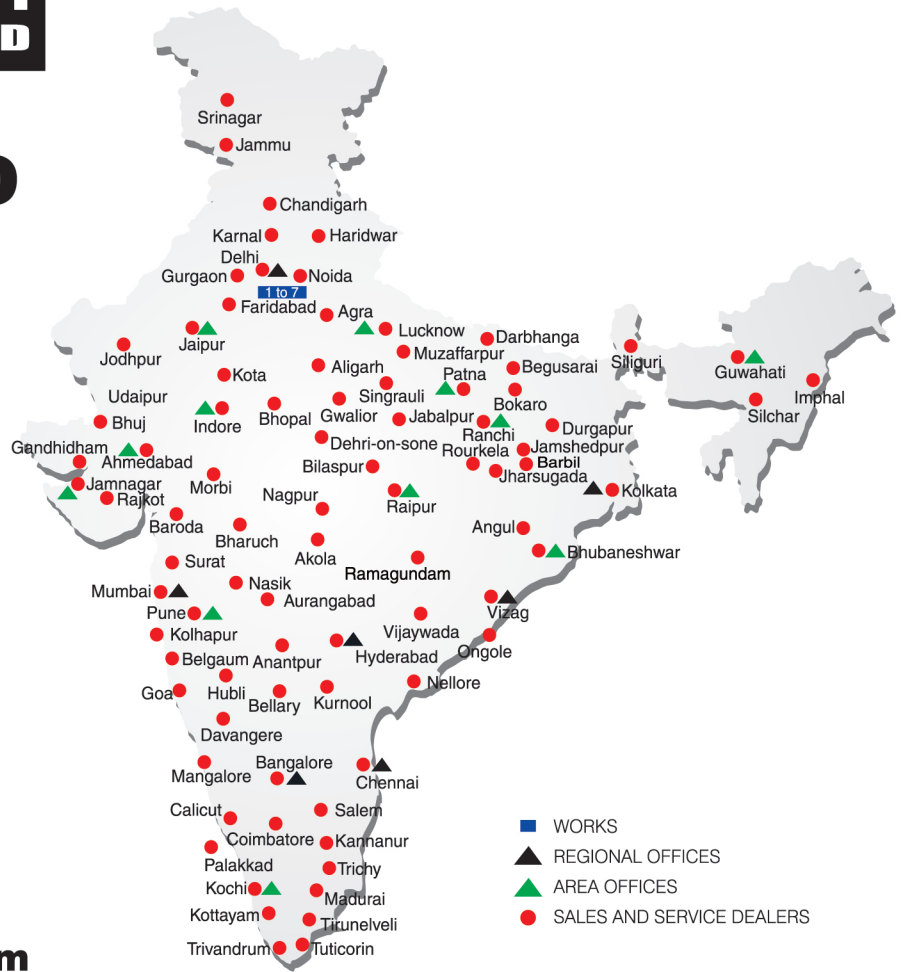

**Toll Free Help Line  
1800 1800 004**

[www.ace-cranes.com](http://www.ace-cranes.com)

### MARKETING H.Q.

4th Floor, Pinnacle  
Surajkund, NCR-121009  
Ph. : +91-129-4550000  
Fax : +91-129-4550022  
E-mail: marketing@ace-cranes.com

### REGISTERED OFFICE

Dudhola Link Road, Dudhola  
Palwal-121102, Haryana  
Ph.: +91-1275-280111  
Fax: +91-1275-280133  
CIN : L74899HR1995PLC053860

### MUMBAI OFFICE

31, "Kalpataru Court"  
Chembur, Mumbai - 400074  
Ph.: +91-22-25206846, 25207070  
Fax: +91-22-25207071  
E-mail: acemumbai@ace-cranes.com

### KOLKATA OFFICE

"Forma Towers" 84-A, Second Floor  
AJC Bose Road, Kolkata - 700014  
Ph.: +91-9038070630  
E-mail: acekolkata@ace-cranes.com

### CHENNAI OFFICE

1st Floor, "Alsa Regency", 165  
Eldams Road, Alwar Pet  
Chennai - 600018  
Ph.: +91-44-24314253  
Fax: +91-44-24314252  
E-mail: acechennai@ace-cranes.com

## HERE TO SERVE YOU.

### SPARE PARTS & SERVICE

ACE has all India Sales and Service network operating out of all the major cities. These outlets are fully equipped to provide genuine spare parts and services by company trained engineers. These outlets are further supported by company officials based at Delhi, Mumbai, Chennai, Kolkatta, Ahmedabad, Surat, Pune, Jaipur, Chandigarh, Ranchi, Raipur, Indore, Bhubneshwar, Lucknow, Jamnagar, Hyderabad, Bangalore, Guwahati, Patna, Vizag & Kochi.



**Action Construction Equipment Ltd.**

Contact:



ACE reserves the right to alter any specifications without prior notice. Dimensions, weights & capacities mentioned herein are variable by ± 5%. Accessories if shown are not part of the Standard Equipment.

AF15E-30E/10/20